

- High Efficiency > 85%
- Self-Contained Inductor
- Short Circuit Protection
- Over-Temperature Protection

The PT79SR100 is a line of Negative Input/Negative Output 3-terminal Integrated Switching

Regulators (ISRs). These ISRs have a maximum output current of -1.5 Amps and an output voltage that is laser trimmed to most industry standard voltages. They have excellent line and load regulation, and are ideal for applications, such as RS232 and Ethernet communications, ECL logic, and op-amp circuitry.

Standard Application

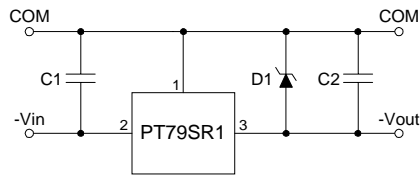

C1 = Optional ceramic (1 μ F)
C2 = Optional ceramic (1-5 μ F)
D1 = Zener diode required to clamp turn-on overshoot (See Application Note)

Pin-Out Information

Pin	Function
1	GND
2	-V _{in}
3	-V _{out}

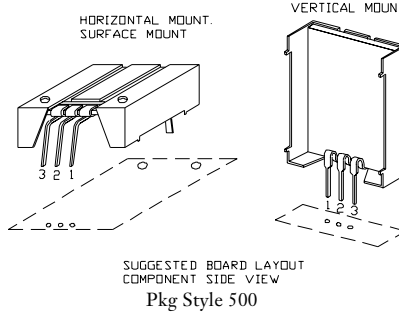

Ordering Information

PT79SR1	XX	Y
Output Voltage		Package Suffix
05 = -5.0 Volts		V = Vertical Mount
52 = -5.2 Volts		S = Surface Mount
06 = -6.0 Volts		H = Horizontal Mount
08 = -8.0 Volts		
09 = -9.0 Volts		
12 = -12.0 Volts		
15 = -15.0 Volts		

Specifications

Characteristics (T _a = 25°C unless noted)	Symbols	Conditions	PT79SR100 SERIES			
			Min	Typ	Max	Units
Output Current	I _o	Over V _{in} range	-0.1*	—	-1.5	A
Short Circuit Current	I _{sc}	V _{in} =V _o -4V	—	-3.5	—	Apk
Input Voltage Range	V _{in}	I _o =-0.1 to -1.5 A -0.1 ≥ I _o ≥ -1.5 A	-9 -19	—	-30 -30	V
Output Voltage Tolerance	ΔV _o	Over V _{in} range, I _o =-1.5 A T _a =20°C to shutdown	—	±1.0	±3.0	%V _o
Line Regulation	Reg _{line}	Over V _{in} range	—	±1.0	±2.0	%V _o
Load Regulation	Reg _{load}	-0.1 ≤ I _o ≤ -1.5 A	—	±0.5	±1.0	%V _o
V _o Ripple/Noise	V _n	V _{in} =-15V, I _o =-1.0 A, V _o =-5V	—	35	—	mV _{pp}
Transient Response	t _{tr}	50% load change V _o =overshoot/undershoot	—	100 30	—	μSec %V _o
Efficiency	η	V _{in} =-10V, I _o =-1.0A, V _o =-5V	—	85	—	%
Switching Frequency	f _o	Over V _{in} and I _o ranges	0.95	1.0	1.05	MHz
Absolute Maximum Operating Temperature Range	T _a		-40	—	+85	°C
Recommended Operating Temperature Range	T _a	Free Air Convection, (40-60LFM) Over V _{in} and I _o ranges	-40	—	+60**	°C
Thermal Resistance	θ _{ja}	Free Air Convection, (40-60LFM)	—	45	—	°C/W
Temperature Coefficient	T _c	Over V _{in} and I _o ranges	—	±0.5	±1.5	mV/°C
Storage Temperature	T _s		-40	—	+125	°C
Mechanical Shock	—	Per Mil-STD-883D, Method 2002.3	—	500	—	G's
Mechanical Vibration	—	Per Mil-STD-883D, Method 2007.2, 20-2000 Hz, soldered in a PC board	—	5	—	G's
Weight	—		—	7.0	—	Grams

* ISR will operate down to no load with reduced specifications.

** See Thermal Derating chart.

-1.5 Amp Negative Step-Down Integrated Switching Regulator

PT79SR105, -5.0 VDC (See Note 1)

Efficiency vs Output Current

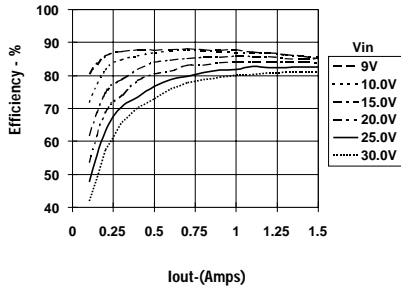

Ripple vs Output Current

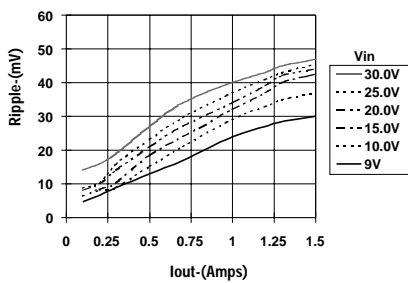

Thermal Derating (Ta) (See Note 2)

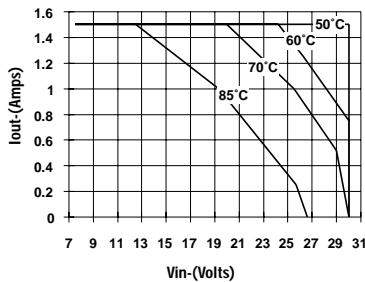

Power Dissipation vs Output Current

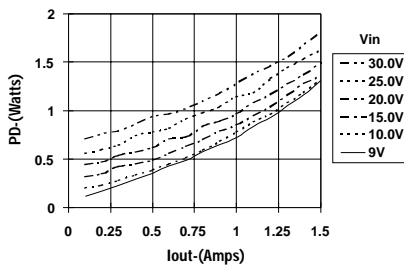

PT79SR112, -12.0 VDC (See Note 1)

Efficiency vs Output Current

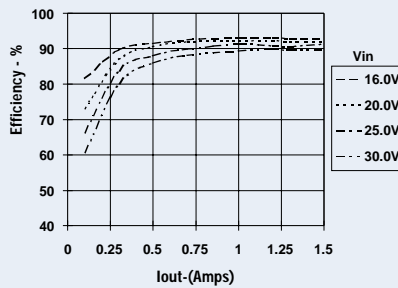

Ripple vs Output Current

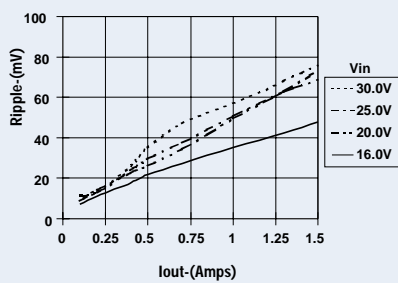

Thermal Derating (Ta) (See Note 2)

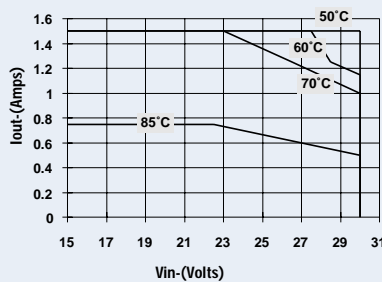

Power Dissipation vs Output Current

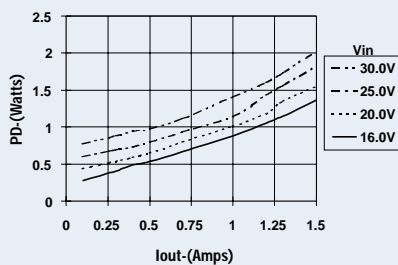

PT79SR115, -15.0 VDC (See Note 1)

Efficiency vs Output Current

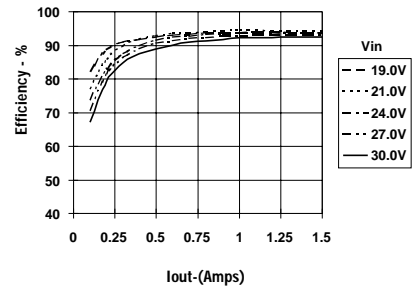

Ripple vs Output Current

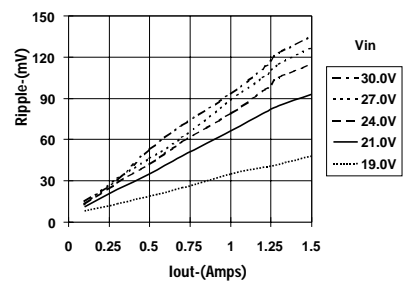

Thermal Derating (Ta) (See Note 2)

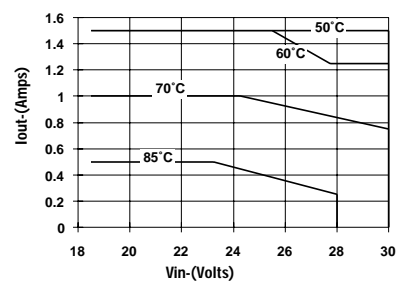

Power Dissipation vs Output Current

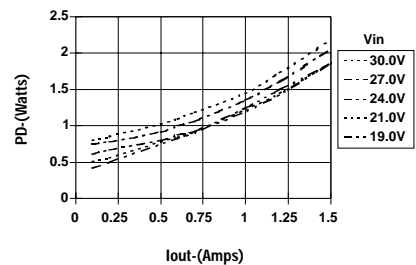

Note 1: All data listed in the above graphs, except for derating data, has been developed from actual products tested at 25°C. This data is considered typical data for the ISR.
 Note 2: Thermal derating graphs are developed in free air convection cooling of 40-60 LFM soldered in a printed circuit board. (See Thermal Application Notes.)